

# 3LF225 -X 6V 225Ah

## General Features

- Positive and negative plates in lead-calcium-tin alloy
- Stable Quality & High Reliability
- Sealed Construction
- Long Service Life
- Maintenance-Free Operation
- Low Pressure Venting System
- Low Self Discharge
- U. L. Component Recognition
- Six months shelf life at 20°C
- Design life 10 years

## SUNNY BATT Rechargeable Products Sealed Lead Acid Battery

The rechargeable batteries are lead-lead dioxide systems. The dilute sulfuric acid electrolyte is absorbed by separators and plates and thus immobilized. Should the battery be accidentally overcharged producing hydrogen and oxygen, special one-way valves allow the gases to escape thus avoiding excessive pressure build-up. Otherwise, the battery is completely sealed and is, therefore, maintenance-free, leak proof and usable in any position.

## General purpose application

SUNNY BATT LF series are designed for general purpose applications, such as UPS, telecom, electrical utilities.

With 10 years design life, the batteries comply to the most popular international standards, such as IEC896-2, BS6290-4, Eurobat Guide.

The battery container and cover are available both in V0 class flame retardant ABS or HBOABS plastics.

come to obtain wide recognition from customers all over the world. This is not only due to the fact that our products are featured by reliable stability in quality, but also because we attach great importance to our communication with customers and our perfect understanding of customers' requirements as well.



## Dimensions and Weight

	SI Units	English Units
Length	320mm	12.6inch
Width	176mm	6.93inch
Height	225mm	8.86inch
Total Height	230mm	9.06inch
Approx. Weight	30.5Kg	67.3lbs

## Performance Characteristics

- Nominal Voltage 6V
- Number of cell 3
- Nominal Capacity 77°F(25°C)
  - 10 hour rate (22.5A, 10.8V) 225Ah
  - 5 hour rate (40.0A, 10.5V) 200Ah
  - 1 hour rate (153A, 9.60V) 153Ah
- Internal Resistance
  - Fully Charged battery 77°F(25°C) 3.2mOhms
- Self-Discharge
  - 3% of capacity declined per month at 20°C(average)
- Operating Temperature Range
  - Discharge -20~60°C
  - Charge -10~60°C
  - Storage -20~60°C
- Max. Discharge Current 77°F(25°C) 1000A(5s)
- Short Circuit Current 3800A
- Charge Methods: Constant Voltage Charge 77°F(25°C)
  - Cycle use 2.30-2.35VPC
  - Maximum charging current 67.5A
  - Temperature compensation -15mV/°C
- Standby use 2.23-2.27VPC
  - Temperature compensation -10mV/°C

## Battery Construction

Component	Positive plate	Negative plate	Container	Cover	Safety valve	Terminal	Separator	Electrolyte
Raw material	Lead dioxide	Lead	ABS	ABS	Rubber	Copper	Fiberglass	Sulfuric acid

# Disch~~DEMO~~ Data

Constant Current Disch~~DEMO~~ Data ( Amperes at 25°C )

End Voltage Per cell / V			15min	20min	25min	30min	35min	40min	45min	50min	55min	1h	1.5h	2h	2.5h	3h	4h	5h	6h	7h	8h	9h	10h	12h	24h
1.60			390	314	269	238	215	198	184	172	161	153	108	84.8	71.1	62.0	49.5	42.0	35.9	31.5	28.3	25.7	23.7	20.2	10.3
1.65			367	297	255	227	207	191	179	166	156	147	104	82.6	69.7	61.1	48.8	41.5	35.5	31.2	27.9	25.4	23.4	19.7	10.1
1.70			358	294	255	230	207	190	176	161	149	139	99.8	80.4	68.7	61.0	48.4	40.8	34.9	30.7	27.5	25.1	23.1	19.4	9.90
1.75			345	282	244	219	196	178	165	155	148	141	101	80.3	68.2	60.1	47.5	40.0	34.3	30.2	27.1	24.7	22.8	19.1	9.80
1.80			299	249	219	199	181	168	157	145	135	126	90.6	72.6	61.9	54.7	45.0	39.1	33.6	29.6	26.7	24.3	22.5	18.8	9.60

Constant Power Disch~~DEMO~~ Data ( Watts per cell at 25°C )

End Voltage Per cell / V			15min	20min	25min	30min	35min	40min	45min	50min	55min	1h	1.5h	2h	2.5h	3h	4h	5h	6h	7h	8h	9h	10h	12h	24h
1.60			677	581	511	465	414	377	348	320	298	279	201	162	138	123	97.1	81.7	69.5	60.8	54.3	49.3	45.2	38.5	20.7
1.65			650	539	472	428	382	348	321	299	280	265	192	156	134	119	95.4	81.1	68.9	60.2	53.7	48.6	44.5	37.8	20.4
1.70			629	521	456	413	371	340	315	293	275	259	186	150	128	113	92.7	80.5	68.3	59.6	53.1	48.0	43.9	37.3	20.1
1.75			608	502	438	396	358	330	308	286	268	254	183	147	126	112	91.4	79.0	67.1	58.6	52.2	47.3	43.3	36.8	19.8
1.80			572	481	426	389	352	324	302	278	258	242	176	143	123	110	89.4	77.0	65.6	57.4	51.3	46.5	42.7	36.3	19.5

(Note)The above characteristics data are average values obtained within three charge/discharge cycles not the minimum values.

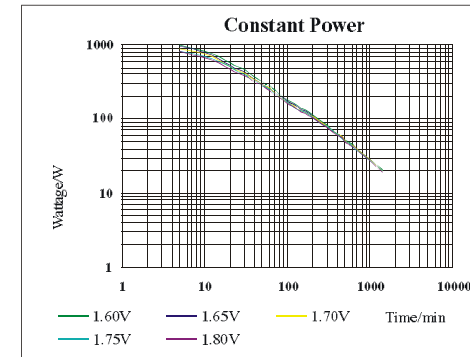
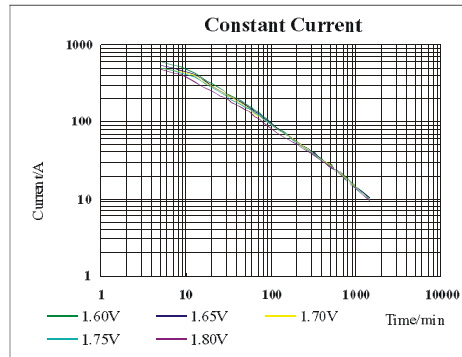
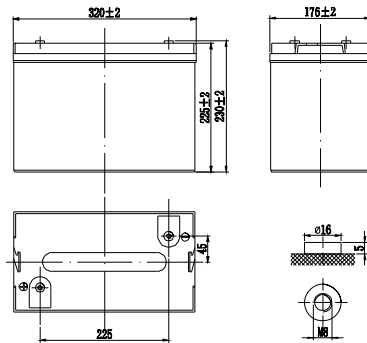

**Discharge characteristic (25°C)**

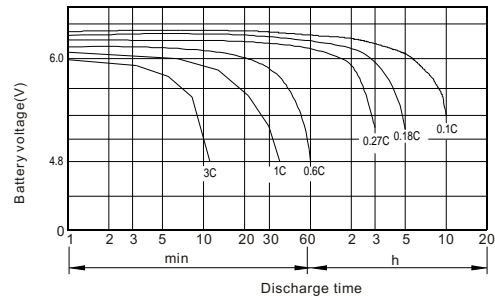

**Temperature effects on float life**

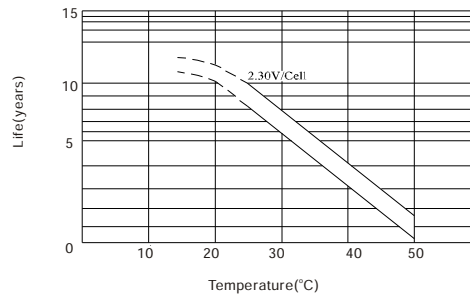

**Cycle service life in relation to depth of discharge**

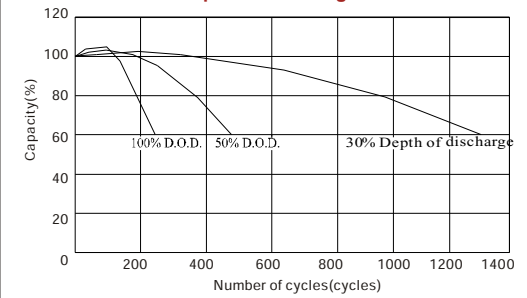

**Relationship between charging voltage and temperature**

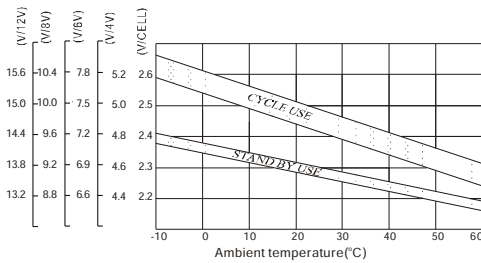

**Constant voltage charging characteristic (0.25CA, 25°C)**

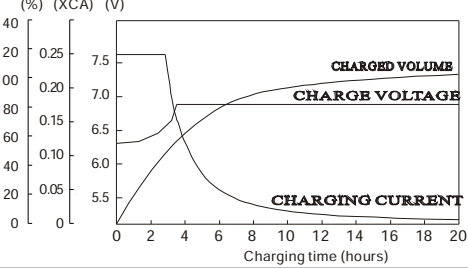

**Temperature effects on capacity**

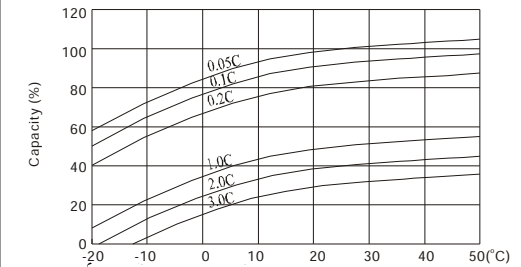

**Life characteristics of Standby use**

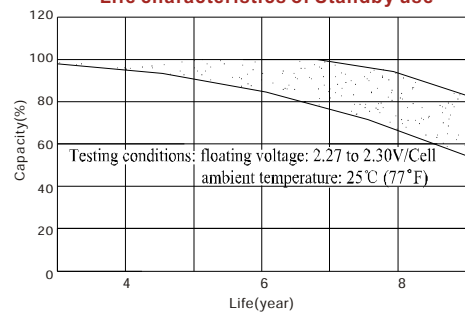

**Self-discharge characteristic**

