

6LF75-X 12V 75Ah

General Features

- Positive and negative plates in lead-calcium-tin alloy
- Stable Quality & High Reliability
- Sealed Construction
- Long Service Life
- Maintenance-Free Operation
- Low Pressure Venting System
- Low Self Discharge
- U. L. Component Recognition
- Six months shelf life at 20°C
- Design life 10 years

Dimensions and Weight

	SI Units	English Units
Length	258mm	10.2inch
Width	166mm	6.54inch
Height	206mm	8.11inch
Total Height	215mm	8.46inch
Approx. Weight	23.5Kg	51.7lbs

Performance Characteristics

- Nominal Voltage 12V
- Number of cell 6
- Nominal Capacity 77°F(25°C)
 - 10 hour rate (7.50A, 10.8V) 75.0Ah
 - 5 hour rate (13.5A, 10.5V) 67.5Ah
 - 1 hour rate (50.2A, 9.60V) 50.2Ah
- Internal Resistance
 - Fully Charged battery 77°F(25°C) 5.7mOhms
- Self-Discharge
 - 3% of capacity declined per month at 20°C(average)
- Operating Temperature Range
 - Discharge -20~60°C
 - Charge -10~60°C
 - Storage -20~60°C
- Max. Discharge Current 77°F(25°C) 700A(5s)
- Short Circuit Current 1800A
- Charge Methods: Constant Voltage Charge 77°F(25°C)
 - Cycle use 14.4-14.7V
 - Maximum charging current 22.5A
 - Temperature compensation -30mV/°C
- Standby use 13.6-13.8V
 - Temperature compensation -20mV/°C

SUNNY BATT Rechargeable Products Sealed Lead Acid Battery

The rechargeable batteries are lead-lead dioxide systems. The dilute sulfuric acid electrolyte is absorbed by separators and plates and thus immobilized. Should the battery be accidentally overcharged producing hydrogen and oxygen, special one-way valves allow the gases to escape thus avoiding excessive pressure build-up. Otherwise, the battery is completely sealed and is, therefore, maintenance-free, leak proof and usable in any position.

General purpose application

SUNNY BATT LF series are designed for general purpose applications, such as UPS, telecom, electrical utilities.

With 10 years design life, the batteries comply to the most popular international standards, such as IEC896-2, BS6290-4, Eurobat Guide.

The battery container and cover are available both in V0 class flame retardant ABS or HBO ABS plastics.

SUNNY BATT GROUP has come to obtain wide recognition from customers all over the world. This is not only due to the fact that our products are featured by reliable stability in quality, but also because we attach great importance to our communication with customers and our perfect understanding of customers' requirements as well.

Battery Construction

Component	Positive plate	Negative plate	Container	Cover	Safety valve	Terminal	Separator	Electrolyte
Raw material	Lead dioxide	Lead	ABS	ABS	Rubber	Pb	Fiberglass	Sulfuric acid

6LF75-X 12V 75Ah

Discharge Data

Constant Current Discharge Data (Amperes at 25°C)

End Voltage Per cell / V	5min	10min	15min	20min	25min	30min	35min	40min	45min	50min	55min	1h	1.5h	2h	2.5h	3h	4h	5h	6h	7h	8h	9h	10h	12h	24h
1.60	240	178	137	109	92.9	81.8	73.2	66.7	61.7	57.1	53.4	50.2	36.0	28.9	24.6	21.8	17.1	14.3	12.1	10.5	9.33	8.41	7.67	6.54	3.52
1.65	222	169	131	104	88.8	78.3	68.9	61.9	56.4	52.8	49.9	47.5	34.5	27.9	24.0	21.4	16.8	14.1	12.0	10.4	9.26	8.37	7.65	6.51	3.50
1.70	206	158	122	99.4	86.0	77.0	67.6	60.5	55.0	51.8	49.1	46.9	33.9	27.5	23.6	21.0	16.6	13.9	11.8	10.3	9.18	8.30	7.60	6.46	3.48
1.75	195	151	117	96.1	83.4	73.6	65.9	59.0	53.7	50.3	47.6	45.3	33.0	26.8	23.1	20.6	16.2	13.5	11.5	10.1	9.04	8.21	7.55	6.42	3.46
1.80	180	139	112	92.6	80.9	73.1	64.6	58.3	53.3	49.3	46.1	43.4	31.6	25.7	22.2	19.8	15.7	13.3	11.4	9.99	8.95	8.14	7.50	6.38	3.43

Constant Power Discharge Data (Watts per cell at 25°C)

End Voltage Per cell / V	5min	10min	15min	20min	25min	30min	35min	40min	45min	50min	55min	1h	1.5h	2h	2.5h	3h	4h	5h	6h	7h	8h	9h	10h	12h	24h
1.60	413	314	246	202	175	158	142	129	120	110	102	95.7	67.9	54.1	45.7	40.2	31.8	26.8	22.9	20.1	18.0	16.4	15.1	12.8	6.90
1.65	403	300	241	197	170	153	138	127	118	108	100	93.6	66.4	52.8	44.6	39.2	31.3	26.6	22.6	19.8	17.7	16.0	14.7	12.5	6.74
1.70	375	290	237	191	163	145	131	120	111	103	95.7	89.8	64.4	51.6	44.0	38.9	30.8	26.0	22.1	19.4	17.3	15.7	14.4	12.3	6.61
1.75	356	274	223	183	158	142	129	119	111	101	93.2	86.5	62.4	50.3	43.1	38.3	30.6	26.0	22.1	19.3	17.2	15.5	14.2	12.0	6.48
1.80	341	261	212	176	155	141	126	115	106	97.5	90.3	84.2	61.1	49.6	42.6	38.0	30.4	25.8	21.8	18.9	16.8	15.1	13.8	11.7	6.30

(Note) The above characteristics data are average values obtained within three charge/discharge cycles not the minimum values.

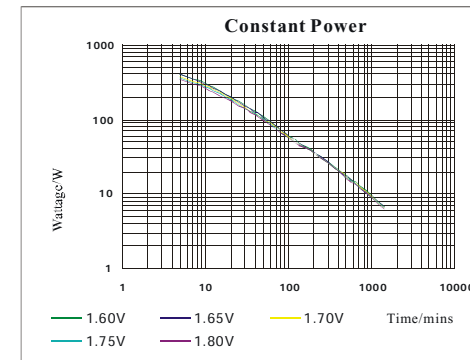
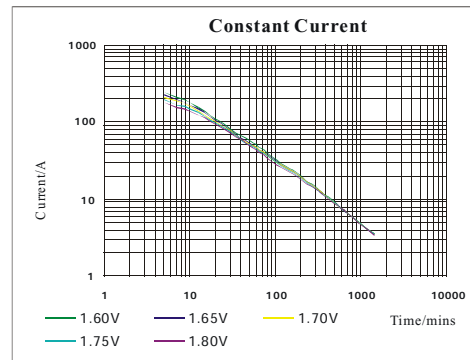
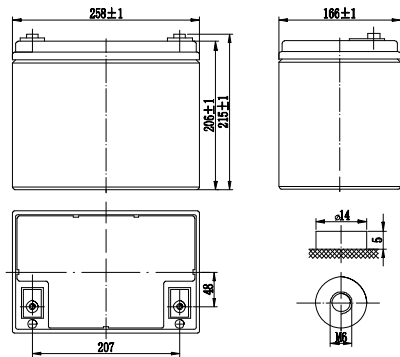

6LF75-X 12V 75Ah

