

6LF65-X 12V 65Ah

General Features

- Positive and negative plates in lead-calcium-tin alloy
- Stable Quality & High Reliability
- Sealed Construction
- Long Service Life
- Maintenance-Free Operation
- Low Pressure Venting System
- Low Self Discharge
- U. L. Component Recognition
- Six months shelf life at 20°C
- Design life 10 years

Dimensions and Weight

	SI Units	English Units
Length	350mm	13.8inch
Width	167mm	6.57inch
Height	179mm	7.05inch
Total Height	179mm	7.05inch
Approx. Weight	23.4Kg	51.6lbs

Performance Characteristics

- Nominal Voltage 12V
- Number of cell 6
- Nominal Capacity 77°F(25°C)
 - 10 hour rate (6.50A, 10.8V) 65.0Ah
 - 5 hour rate (11.3A, 10.5V) 56.5Ah
 - 1 hour rate (44.2A, 9.60V) 44.2Ah
- Internal Resistance
 - Fully Charged battery 77°F(25°C) 6mOhms
- Self-Discharge
 - 3% of capacity declined per month at 20°C(average)
- Operating Temperature Range
 - Discharge -20~60°C
 - Charge -10~60°C
 - Storage -20~60°C
- Max. Discharge Current 77°F(25°C) 650A(5s)
- Short Circuit Current 1700A
- Charge Methods: Constant Voltage Charge 77°F(25°C)
 - Cycle use 14.4-14.7V
 - Maximum charging current 19.5A
 - Temperature compensation -30mV/°C
- Standby use 13.6-13.8V
 - Temperature compensation -20mV/°C

Battery Construction

Component	Positive plate	Negative plate	Container	Cover	Safety valve	Terminal	Separator	Electrolyte
Raw material	Lead dioxide	Lead	ABS	ABS	Rubber	Copper	Fiberglass	Sulfuric acid

SUNNY BATT Rechargeable Products Sealed Lead Acid Battery

The rechargeable batteries are lead-lead dioxide systems. The dilute sulfuric acid electrolyte is absorbed by separators and plates and thus immobilized. Should the battery be accidentally overcharged producing hydrogen and oxygen, special one-way valves allow the gases to escape thus avoiding excessive pressure build-up. Otherwise, the battery is completely sealed and is, therefore, maintenance-free, leak proof and usable in any position.

General purpose application

SYNNY BATT LF series are designed for general purpose applications, such as UPS, telecom, electrical utilities.

With 10 years design life, the batteries comply to the most popular international standards, such as IEC896-2, BS6290-4, Eurobat Guide.

The battery container and cover are available both in V0 class flame retardant ABS or HBO ABS plastics.

SUNNY BATT GROUP has come to obtain wide recognition from customers all over the world. This is not only due to the fact that our products are featured by reliable stability in quality, but also because we attach great importance to our communication with customers and our perfect understanding of customers' requirements as well.

6LF65-X 12V 65Ah

Discharge Data

Constant Current Discharge Data (Amperes at 25°C)																									
End Voltage Per cell / V	5min	10min	15min	20min	25min	30min	35min	40min	45min	50min	55min	1h	1.5h	2h	2.5h	3h	4h	5h	6h	7h	8h	9h	10h	12h	24h
1.60	215	160	125	97.8	81.4	70.5	63.0	57.4	53.0	49.5	46.6	44.2	30.9	24.3	20.3	17.7	14.2	12.1	10.4	9.19	8.28	7.58	7.01	5.90	3.20
1.65	203	151	116	92.2	77.7	68.0	61.5	56.6	52.8	48.5	44.9	41.9	29.5	23.3	19.6	17.1	13.7	11.7	10.1	8.96	8.10	7.43	6.90	5.81	3.12
1.70	191	143	114	90.2	75.8	66.3	59.4	54.2	50.1	46.7	43.8	41.5	29.2	23.1	19.4	16.9	13.5	11.5	9.92	8.79	7.95	7.29	6.76	5.75	3.06
1.75	178	132	108	87.1	74.6	66.2	59.2	53.9	49.8	46.2	43.3	40.9	28.8	22.8	19.2	16.7	13.3	11.3	9.74	8.62	7.78	7.13	6.61	5.62	2.97
1.80	165	120	100	80.9	69.4	61.8	55.6	50.9	47.3	43.7	40.7	38.3	27.3	21.8	18.5	16.3	13.0	11.1	9.57	8.47	7.65	7.01	6.50	5.53	2.86

Constant Power Discharge Data (Watts per cell at 25°C)																									
End Voltage Per cell / V	5min	10min	15min	20min	25min	30min	35min	40min	45min	50min	55min	1h	1.5h	2h	2.5h	3h	4h	5h	6h	7h	8h	9h	10h	12h	24h
1.60	381	282	222	177	150	132	117	106	98.0	91.1	85.5	80.8	57.7	46.1	39.1	34.5	27.2	22.8	19.6	17.3	15.5	14.2	13.1	11.1	5.98
1.65	359	267	206	166	143	127	114	104	96.5	89.5	83.8	79.0	56.4	45.1	38.3	33.8	26.8	22.6	19.4	17.1	15.3	14.0	12.9	11.0	5.90
1.70	337	252	197	158	134	118	108	100	94.5	87.6	81.9	77.2	55.5	44.6	38.1	33.7	26.6	22.4	19.2	16.9	15.2	13.9	12.8	10.9	5.88
1.75	315	237	193	155	131	116	106	98.3	92.4	85.6	80.0	75.4	53.9	43.2	36.7	32.4	25.9	22.0	18.9	16.7	15.0	13.7	12.7	10.8	5.84
1.80	294	220	183	149	128	114	104	96.9	91.2	84.7	79.4	75.0	53.4	42.5	36.0	31.7	25.5	21.7	18.7	16.5	14.9	13.6	12.6	10.7	5.78

(Note) The above characteristics data are average values obtained within three charge/discharge cycles not the minimum values.

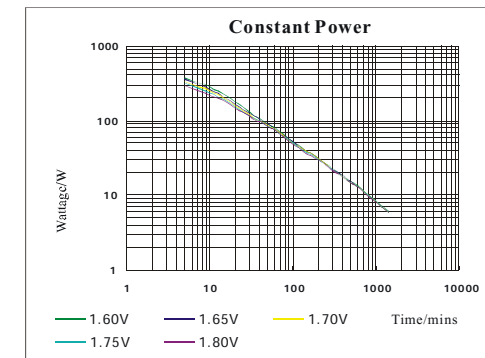
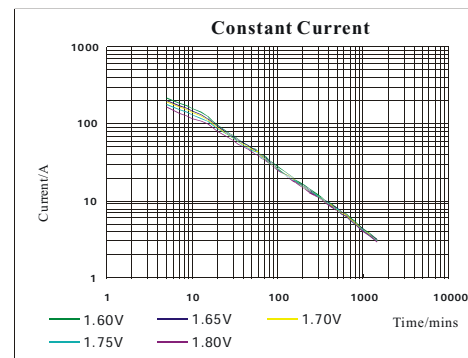
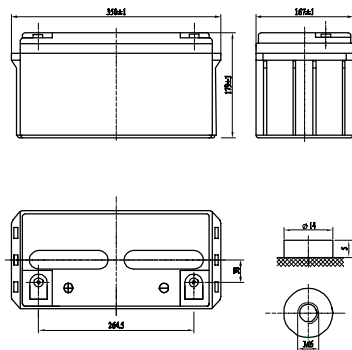

6LF65-X 12V 65Ah

