

# 6LF100-X 12V 100Ah

## General Features

- Positive and negative plates in lead-calcium-tin alloy
- Stable Quality & High Reliability
- Sealed Construction
- Long Service Life
- Maintenance-Free Operation
- Low Pressure Venting System
- Low Self Discharge
- U. L. Component Recognition
- Six months shelf life at 20°C
- Design life 10 years

## Dimensions and Weight

	SI Units	English Units
Length	330mm	13.0inch
Width	171mm	6.73inch
Height	215mm	8.46inch
Total Height	220mm	8.66inch
Approx. Weight	32.0Kg	70.6lbs



## Performance Characteristics

- Nominal Voltage 12V
- Number of cell 6
- Nominal Capacity 77°F(25°C)
  - 10 hour rate (10.0A, 10.8V) 100Ah
  - 5 hour rate (17.5A, 10.5V) 87.5Ah
  - 1 hour rate (66.2A, 9.60V) 66.2Ah
- Internal Resistance
  - Fully Charged battery 77°F(25°C)5mOhms
- Self-Discharge
  - 3% of capacity declined per month at 20°C(average)
- Operating Temperature Range
  - Discharge -20~60°C
  - Charge -10~60°C
  - Storage -20~60°C
- Max. Discharge Current 77°F(25°C) 900A(5s)
- Short Circuit Current 2100A
- Charge Methods: Constant Voltage Charge 77°F(25°C)
  - Cycle use 14.4-14.7V
  - Maximum charging current 30A
  - Temperature compensation -30mV/°C
- Standby use 13.6-13.8V
  - Temperature compensation -20mV/°C

## Battery Construction

Component	Positive plate	Negative plate	Container	Cover	Safety valve	Terminal	Separator	Electrolyte
Raw material	Lead dioxide	Lead	ABS	ABS	Rubber	Copper	Fiberglass	Sulfuric acid

## SUNNY BATT Rechargeable Products Sealed Lead Acid Battery

The rechargeable batteries are lead-lead dioxide systems. The dilute sulfuric acid electrolyte is absorbed by separators and plates and thus immobilized. Should the battery be accidentally overcharged producing hydrogen and oxygen, special one-way valves allow the gases to escape thus avoiding excessive pressure build-up. Otherwise, the battery is completely sealed and is, therefore, maintenance-free, leak proof and usable in any position.

## General purpose application

SUNNY BATT LF series are designed for general purpose applications, such as UPS, telecom, electrical utilities.

With 10 years design life, the batteries comply to the most popular international standards, such as IEC896-2, BS6290-4, Eurobat Guide.

The battery container and cover are available both in V0 class flame retardant ABS or HBO ABS plastics.

SUNNY BATT GROUP has come to obtain wide recognition from customers all over the world. This is not only due to the fact that our products are featured by reliable stability in quality, but also because we attach great importance to our communication with customers and our perfect understanding of customers' requirements as well.

# 6LF100-X 12V 100Ah

## Discharge Data

Constant Current Discharge Data ( Amperes at 25°C )																									
End Voltage Per cell / V		10min	15min	20min	25min	30min	35min	40min	45min	50min	55min	1h	1.5h	2h	2.5h	3h	4h	5h	6h	7h	8h	9h	10h	12h	24h
1.60		229	185	146	123	108	96.3	87.4	80.5	74.8	70.1	66.2	47.1	37.5	31.8	27.9	22.4	19.0	16.3	14.3	12.9	11.7	10.8	9.06	4.70
1.65		221	178	141	119	104	93.2	85.0	78.7	72.2	66.9	62.5	45.1	36.4	31.2	27.7	21.8	18.3	15.7	13.9	12.5	11.5	10.6	9.01	4.68
1.70		200	164	130	110	96.0	86.1	78.8	73.0	68.4	64.6	61.5	44.4	35.8	30.6	27.2	21.5	18.0	15.5	13.7	12.4	11.3	10.5	8.93	4.59
1.75		187	153	123	105	93.0	83.7	76.7	71.3	67.0	63.4	60.5	43.7	35.3	30.2	26.9	21.0	17.5	15.1	13.4	12.1	11.1	10.3	8.76	4.50
1.80		175	143	117	101	91.0	82.0	75.3	70.0	65.0	60.8	57.4	41.4	33.3	28.5	25.3	20.2	17.2	14.8	13.1	11.8	10.8	10.0	8.50	4.42

Constant Power Discharge Data ( Watts per cell at 25°C )																									
End Voltage Per cell / V		10min	15min	20min	25min	30min	35min	40min	45min	50min	55min	1h	1.5h	2h	2.5h	3h	4h	5h	6h	7h	8h	9h	10h	12h	24h
1.60		392	321	260	223	199	178	162	150	140	131	124	88.4	70.6	60.0	52.8	42.2	35.8	30.6	26.9	24.2	22.0	20.3	17.4	9.25
1.65		379	315	252	213	188	170	156	146	135	125	118	84.5	67.8	57.8	51.2	41.3	35.4	30.3	26.7	23.9	21.8	20.1	17.1	9.20
1.70		360	299	241	206	183	163	149	137	128	121	114	82.6	66.8	57.3	50.9	41.0	35.0	30.0	26.4	23.8	21.7	20.0	17.0	9.13
1.75		353	294	236	200	177	159	145	134	125	117	111	80.0	64.5	55.3	49.1	39.9	34.4	29.4	25.9	23.3	21.2	19.6	16.7	8.98
1.80		329	279	225	193	171	154	141	131	120	112	104	76.5	62.5	54.1	48.5	39.4	34.0	29.0	25.5	22.8	20.8	19.1	16.2	8.74

(Note) The above characteristics data are average values obtained within three charge/discharge cycles not the minimum values.

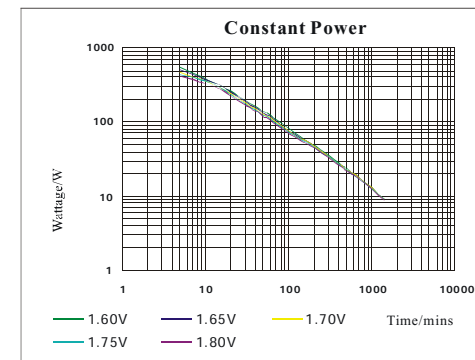
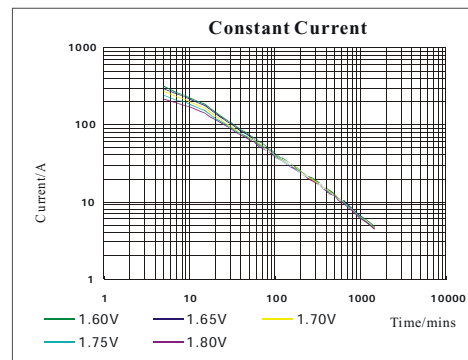
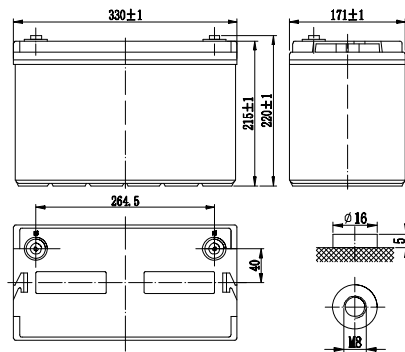

# 6LF100 -X12V 100Ah

