

# SG2-600 2V 600Ah(10hr)

Gel battery shows some distinctive advantages over flooded battery or AGM battery, such as super thermal stability, high deep discharge capability, good recovery from deep discharge, even if the battery is left discharged for three days, it will recover to 100% of capacity. With the above-mentioned advantages, the gel battery has long service life, specially suitable for motive power applications, such as golf trailer, sruubber, folklift, etc. The deep discharge cycles increased 50% as compared with the AGM battery.

## Battery Construction

Component	Positive plate	Negative plate	Container	Cover	Safety valve	Terminal	Separator	Electrolyte
Raw material	Lead dioxide	Lead	ABS	ABS	Rubber	Copper	PVC	Gelled acid

## General Features

- Nanometer SiO<sub>2</sub> and H<sub>2</sub>SO<sub>4</sub> gelled electrolyte technology for efficiency gas recombination of up to 99% and freedom from electrolyte maintenance or water adding.
- Not restricted for air transport-complies with IATA/ICAO Special Provision A67.
- UL-recognized component.
- Can be mounted in any orientation.
- Computer designed lead, calcium tin alloy grid for high power density.
- Long service life, float or cyclic applications.
- Maintenance-free operation.
- Low self discharge.
- Case and cover available in both standard and flame retardant ABS.

## Dimensions and Weight

Length(mm / inch) ..... 302 / 11.9  
 Width(mm / inch) ..... 175 / 6.89  
 Height(mm / inch) ..... 330 / 13.0  
 Total Height(mm / inch) ..... 367 / 14.5  
 Approx. Weight(Kg / lbs) ..... 40 / 88.2

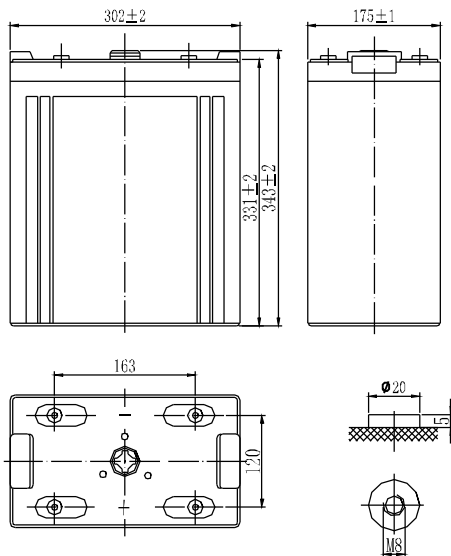

Total height with removable cover: 367

## Performance Characteristics

Nominal Voltage	2V
Number of cell	1
Design Life	20 years
Nominal Capacity 77°F(25°C)	
10 hour rate (60.0A, 1.80V)	600Ah
5 hour rate (106A, 1.75V)	530Ah
1 hour rate (372A, 1.60V)	372Ah
Internal Resistance	
Fully Charged battery 77°F(25°C)	0.6mOhms
Self-Discharge	
2% of capacity declined per month at 20°C(average)	
Operating Temperature Range	
Discharge	-20~60°C
Charge	-10~60°C
Storage	-20~60°C
Max. Discharge Current 77°F(25°C)	2200A(5s)
Charge Methods: Constant Voltage Charge 77°F(25°C)	
Cycle use Charge Voltage:	2.40V-2.45V
Maximum charging current	120A
Temperature compensation	-5mV/°C
Standby use	2.25V-2.30V
No charge current limit is required	
Temperature compensation	-3.3mV/°C

## Discharge Constant Current (Amperes at 77°F25°C)

End point volts/cell	10min	15min	30min	1h	3h	5h	10h	20h
1.60V	1260	1032	600	372	156	114	63.0	33.6
1.65V	1188	960	588	360	152	110	62.4	33.0
1.70V	1116	912	576	348	148	108	61.2	32.4
1.75V	1044	840	564	336	146	106	60.6	32.1
1.80V	972	768	540	318	140	102	60.0	31.5

## Discharge Constant Power (Watts at 77°F25°C)

End point volts/cell	10min	15min	30min	1h	3h	5h	10h	20h
1.60V	2157	1750	1123	696	292	219	122	66.1
1.65V	2053	1736	1073	662	277	207	111	62.3
1.70V	2000	1663	1023	635	263	197	109	59.6
1.75V	1904	1559	993	613	250	193	105	57.5
1.80V	1804	1475	950	585	235	180	97.9	55.4

(Note)The above characteristics data are average values obtained within three charge/discharge cycles not the minimum values.

# SG2-600 2V600Ah

