

SG2-500 2V 500Ah(10hr)

Gel battery shows some distinctive advantages over flooded battery or AGM battery, such as super thermal stability, high deep discharge capability, good recovery from deep discharge, even if the battery is left discharged for three days, it will recover to 100% of capacity. With the above-mentioned advantages, the gel battery has long service life, specially suitable for motive power applications, such as golf trailer, sruubber, folklift, etc. The deep discharge cycles increased 50% as compared with the AGM battery.

Battery Construction

Component	Positive plate	Negative plate	Container	Cover	Safety valve	Terminal	Separator	Electrolyte
Raw material	Lead dioxide	Lead	ABS	ABS	Rubber	Copper	PVC	Gelled acid

General Features

- Nanometer SiO₂ and H₂SO₄ gelled electrolyte technology for efficiency gas recombination of up to 99% and freedom from electrolyte maintenance or water adding.
- Not restricted for air transport-complies with IATA/ICAO Special Provision A67.
- UL-recognized component.
- Can be mounted in any orientation.
- Computer designed lead, calcium tin alloy grid for high power density.
- Long service life, float or cyclic applications.
- Maintenance-free operation.
- Low self discharge.
- Case and cover available in both standard and flame retardant ABS.

Dimensions and Weight

Length(mm / inch)	242 / 9.53
Width(mm / inch)	173 / 6.81
Height(mm / inch)	330 / 13.0
Total Height(mm / inch)	365 / 14.4
Approx. Weight(Kg / lbs)	31 / 68.4

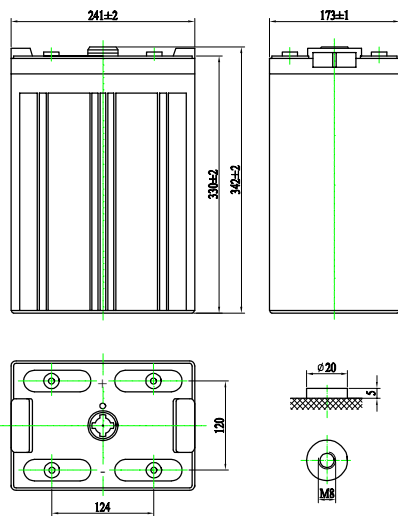

Total height with removable cover: 365

Performance Characteristics

Nominal Voltage	2V
Number of cell	1
Design Life	20 years
Nominal Capacity 77°F(25°C)	
10 hour rate (50.0A, 1.80V)	500Ah
5 hour rate (88.0A, 1.75V)	440Ah
1 hour rate (310A, 1.60V)	310Ah
Internal Resistance	
Fully Charged battery 77°F(25°C)	0.65mOhms
Self-Discharge	
2% of capacity declined per month at 20°C(average)	
Operating Temperature Range	
Discharge	-20~60°C
Charge	-10~60°C
Storage	-20~60°C
Max. Discharge Current 77°F(25°C)	1800A(5s)
Charge Methods: Constant Voltage Charge 77°F(25°C)	
Cycle use Charge Voltage:	2.40V-2.45V
Maximum charging current	100A
Temperature compensation	-5mV/°C
Standby use	2.25V-2.30V
No charge current limit is required	
Temperature compensation	-3.3mV/°C

Discharge Constant Current (Amperes at 77°F25°C)

End point volts/cell	10min	15min	30min	1h	3h	5h	10h	20h
1.60V	1050	860	500	310	130	95.0	52.5	28.0
1.65V	990	800	490	300	127	92.0	52.0	27.5
1.70V	930	760	480	290	123	90.0	51.0	27.0
1.75V	870	700	470	280	122	88.0	50.5	26.8
1.80V	810	640	450	265	117	85.0	50.0	26.3

Discharge Constant Power (Watts at 77°F25°C)

End point volts/cell	10min	15min	30min	1h	3h	5h	10h	20h
1.60V	1798	1459	936	580	243	182	102	55.1
1.65V	1711	1446	894	552	231	172	92.4	51.9
1.70V	1667	1386	852	529	219	164	90.6	49.7
1.75V	1587	1299	827	511	208	161	87.3	47.9
1.80V	1503	1229	792	488	196	150	81.6	46.2

(Note)The above characteristics data are average values obtained within three charge/discharge cycles not the minimum values.

SG2-500 2V500Ah

